

# XIM Range - Plastic Mixed Flow Fans

## Key Features

<b>Type:</b>	Plastic in-line.
<b>Application:</b>	Commercial/ industrial.
<b>Control options:</b>	Speed control & humidity/ PIR sensing.
<b>Speed control:</b>	XIC1
<b>Humidity:</b>	XPI RA
<b>Movement:</b>	XRH
<b>Time delay:</b>	DT20



## XPELAIR XIM Range

Traditionally centrifugal ducted systems have been bulky and noisy but not any more.

The new low profile Xpelair XIM units provide plenty of useable power for domestic ducted applications and save space too.

These models are ideal for ducted applications where space is limited such as bathrooms, shower rooms, kitchens and other internal rooms without opening windows.

All models come complete with a convenient mounting cradle.

They are dimensionally smaller than centrifugal units and with lower sound levels these units can often eliminate the need for a silencer.

The plastic construction will not deteriorate in high humidity conditions. All models are IP55 rated. They are double insulated and suitable for 220V-240V 50Hz mains operation and suitable for operation in ambient temperatures up to 40°C and are fitted with a thermal overload protection.

## Performance

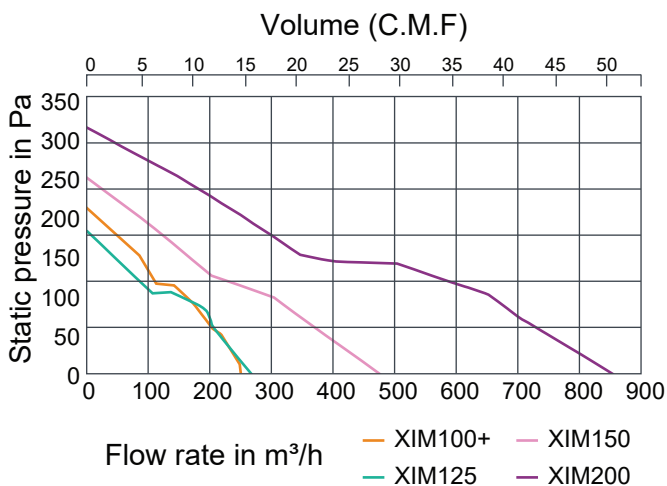

## Specifications

	XIM100+	XIM125	XIM150	XIM200
UK reference number:	91254AW	91255AW	91256AW	91258AW
Speeds:	2	2	2	2
Duct size diameter (mm):	100	125	150	200
Max. extract performance (m³/h):	251	265	476	845
Min. extract performance (m³/h):	190	198	358	599
Sound pressure level (dB (A)@3m) high:	22	25	39	39
Electrical power rating (W):	25	25	80	80
Weight (kg):	2.1	2.1	3.2	4.5

# XIM Range - Plastic Mixed Flow Fans

## Key Features

XIM100+ / 125 / 150 / 200  
Ref. 91245AW

- High performance 2 speed in-line plastic fan.
- Mixed flow impeller/ guide vanes.
- Integral mounting cradle.
- Rated IPX4.
- Supply voltage: 220-240V 50Hz.

## Dimensions (mm)

XIM 100+/125

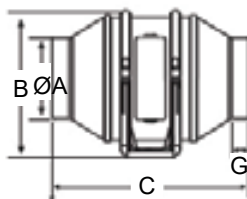
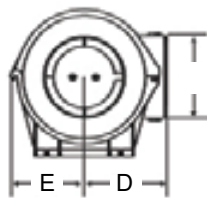

XIM 150/200

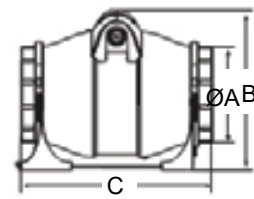

Model:	ØA	B	C	D	E	F	G
XIM100+:	98	217	262.4	100	100	168.3	21.3
XIM125:	122	217	262.4	100	100	168.3	21.3
XIM150:	147	244	293.4	130	115	192.3	21.3
XIM200:	197	278.5	363.6	142	140	230.2	51.5

## Installation

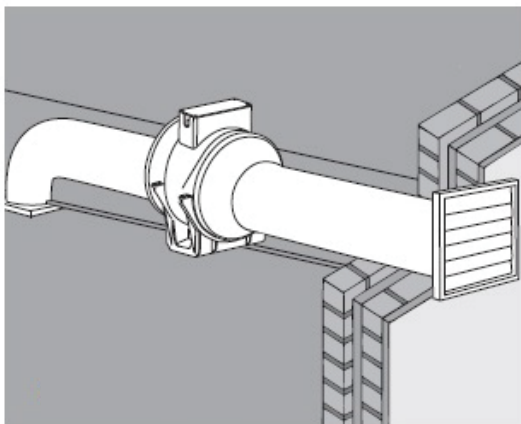

### XIM ceiling installation

#### Ceiling mounting

Flexible ducting	FD100	(Use with XIM100+)
Flexible ducting	FD125	(Use with XIM125)
Flexible ducting	FD150	(Use with XIM150)
Flexible ducting	FD200	(Use with XIM200)
Wall grille	CFWG100	(Use with XIM100)
Wall grille	CFWG150	(Use with XIM150)
Louvre grille	XLG125	(Use with XIM125)
Louvre grille	XLG150	(Use with XIM150)
Grille	XLG200	(Use with XIM200)